

HOLY NAME OF MARY CATHOLIC SECONDARY SCHOOL

115 GLENVALE BLVD, BRAMPTON, ONTARIO, L6S 3J7

TELEPHONE: (905) 458-5541 FAX: (905) 458-4741



COURSE CALENDAR GRADE NINE, TEN ELEVEN AND TWELVE 2009-2010

PRINCIPAL:

S. GOS

VICE-PRINCIPAL:

R. BORG

THE DUFFERIN-PEEL
CATHOLIC DISTRICT SCHOOL BOARD

TABLE OF CONTENTS

Principal’s Message	1
School Philosophy	1
Admission/Registration	2
The Credit System	3
Types of Courses.....	3
Organization of Courses	3
Ontario Student Transcript.....	4
Ontario Student Record	4
Full Disclosure.....	4
Evaluation	4
Requirements For Ontario Secondary School Diploma	5
Grade 10 Literacy Test.....	5
Community Involvement	5
Information About Dufferin Peel’s Special Education Advisory Committee	5
Requirements For Ontario Secondary School Certificate of Accomplishment.....	6
Minimum Course Loads	7
Course Coding	7
Summary Of Courses.....	8
Educational Planner	11
Course Selection And Program Planning	12
Guidance And Career Education	13
Academic Resource And Alternative Programs	14
Learning Strategies	14
Business Studies	15
Canadian & World Studies	17
Classical Studies and International Languages	19
Co-operative Education	20
English	20
English as a Second Language	22
French as a Second Language	23
Guidance and Career Education	24
Interdisciplinary Studies	24
Mathematics.....	25
Physical and Health Education	27
Religious Education	28
Science	30
Social Sciences And Humanities	32
Technological Education.....	33
Visual and Performing Arts	34

HOLY NAME OF MARY CATHOLIC SECONDARY SCHOOL
“Aspires to act justly, love tenderly and walk humbly with our God”

PRINCIPAL’S MESSAGE

Dear Students and Parents,

Holy Name of Mary Catholic Secondary School is a Catholic learning community dedicated to providing unique opportunities for young women to earn their Ontario Secondary School Diploma. Our focus on career exploration, involvement in co-curricular activities and commitment to the pursuit of personal leadership is designed to support learners to grow in faith and to become problem solvers and decision makers. Each individual in our learning community has an obligation to learn and to grow spiritually, emotionally, intellectually, morally and socially to better serve one another and the greater society.

Making informed choices regarding life destinations remains critical. We invite students, parents, teachers and school support personnel to join in a collaborative discourse to ensure sound and effective decision making. A great deal of thought and hard work has gone into preparing this course calendar to assist you in making appropriate decisions and planning for a successful school career. We encourage you to use this book wisely and well!

S. Gos
Principal

OUR SCHOOL PHILOSOPHY

A Catholic school is one that tries to be conscious of its prophetic function to challenge, to encourage, and to instill in the young people it serves, a Christian vision of all aspects of human existence. We try to build a faith community within our school hoping its spirit will extend beyond the confines of the building. Thus, we direct our efforts toward providing the best available conditions for the total development of every student. As a result, we are committed to helping the students grow spiritually as well as academically, emotionally, physically and socially. We strive to develop a warm atmosphere where firm discipline goes hand in hand with compassion. In a school dedicated to Mary, we would like to encourage one another to grow in gentleness and courage, to show concern for one another and to respect each individual for his/her own unique abilities and needs.

The student at Holy Name of Mary Catholic Secondary School is continuing her spiritual journey towards a greater understanding of God, self and others.

As she ventures forth from this community, she will be prepared to meet the challenges of the future in the fundamentals of life: charity, communication and creativity.

CHARITY: She will

- a) understand the importance of tolerance and love in her relationships with all people;
- b) be able to look at the world through the eyes of others, appreciating differences and working towards the elimination of prejudice;
- c) appreciate the importance of her participation in the community not only as a responsible, law abiding citizen, but also as a concerned woman who reflects Gospel values in her ability to question, criticize, support and develop social and political plans and policies.

COMMUNICATION: She will

- a) recognize, value and appreciate the importance of religious heritage and literacy;
- b) have the power of literacy in print, media and technology so that she can understand and function in the world in which she lives, thereby having the confidence to articulate her own unique thoughts and the freedom to control her destiny.

CREATIVITY: She will

- a) understand the importance of disciplined imagination in becoming a complete person;
- b) anticipate problems and envision solutions which integrate knowledge and skills from a variety of subject areas;
- c) recognize the value of being a well-rounded individual who sees the talents and possibilities within herself and others;
- d) value a sense of awe, wonder and spirituality.

2009-2010

ADMISSION/REGISTRATION PROCEDURES

Holy Name of Mary is a regional secondary school for young women to which applications may be submitted from eligible students throughout Peel and Dufferin counties. The maximum enrolment is 840 students comprising students presently enrolled as well as new registrants.

A. GRADE EIGHT STUDENTS APPLYING FOR ENTRY TO GRADE NINE

1. Information nights are scheduled at Holy Name of Mary Catholic Secondary School for parents/guardians of grade eight students:
Wednesday, November 26, 2008
2. Registration for Grade 8 students enrolled in Dufferin-Peel Catholic District School Board schools will take place on Tuesday, January 13th 2009 from 10:00 a.m. until 7:00 p.m. and on Wednesday, January 14th, 2009 from 8:00 a.m. until 4:30 p.m. You must submit a registration form, course selection form, and the \$60.00 activity fee.
3. Registration for Grade 8 students from other schools in Dufferin or Peel county will take place beginning on Monday, January 19, 2009 from 8:00 a.m. until 4:00 p.m.

B. HOLY NAME OF MARY STUDENTS REGISTERING FOR GRADES 10–12

1. *Returning students must submit Course Selection forms* (signed by parent/guardian, if the student is under eighteen years of age), plus the non-refundable activity fee by *Friday, December 12th, 2008* at noon indicating course selection. Students who submit their Course Selection forms by this date and time are guaranteed a place.
2. Parents/Guardians of students who have not returned a Course Selection form by December 12th, 2008 will be called by Tuesday, December 16th, 2008 reminding them of the past due date and the consequences.
3. Students who have not submitted a Course Selection form by the end of the school day on Tuesday, December 16th, 2008, and who wish to return to Holy Name of Mary will be placed on the appropriate grade wait list with students from other schools.

THE CREDIT SYSTEM

DEFINITION OF A CREDIT/EQUIVALENT CREDIT

A credit is granted to a student by the Principal in recognition of the successful completion of a course for which a minimum of 110 hours has been scheduled. Half credits reflect a proportionate number of hours of instruction.

COMPULSORY CREDIT

A credit that is earned for the successful completion of the expectations related to a compulsory course. Compulsory courses are those that must be included in a student's program.

OPTIONAL CREDIT

A credit that is earned for the successful completion of an optional course. Optional courses are those selected from available courses, apart from compulsory courses.

TYPES OF COURSES

The types of courses offered and their organization provide for a graduated streaming of courses in Grades 9 to 12 that will keep options open for all students in the earlier grades and prepare students in senior grades for their future destination.

Grades 9 & 10

Students in Grade 9 & 10 will choose courses from one or more of four types: academic, applied, open and locally developed.

Academic (D) courses focus on the essential concepts of the discipline plus additional related concepts. They develop students' knowledge and skills by emphasizing theoretical, abstract applications of the essential concepts while incorporating practical applications as appropriate.

Applied (P) courses also focus on the essential concepts of the discipline. They develop students' knowledge and skills by emphasizing practical, concrete applications of the essential concepts while incorporating theoretical applications as appropriate.

Open (O) courses are designed to prepare students for further study in certain subjects. An open course has one set of expectations for that subject and is appropriate for all students.

Students who are successful in any academic or applied course in grade 9 will be able to proceed to either the academic or the applied course in the same subject in Grade 10. When a student plans to switch from one course type in grade 9 to another in grade 10, however, she should complete additional course work as defined by the Ministry of Education of up to 30 hours. This additional course work is called crossover material and is available through the internet at www.ilc.org.

When a student plans to switch from one course type in grade 10 to another in grade 11, she must complete additional course work as defined by the Ministry of Education. This additional course work is called a transfer course. Similarly, when a student wishes to switch from one course type in grade 11 to another in grade 12, she must complete a transfer course.

Essential courses are locally developed courses offered to meet the educational or career preparation needs of students. Locally developed courses are available in English, Mathematics and Science.

Grades 11 & 12

University Preparation Courses: These courses equip students with the

knowledge and skills they need to meet the entrance requirements for university programs.

University/College Preparation Courses: These courses are designed to equip students with the knowledge and skills they need to meet the entrance requirements of specific university and college programs.

College Preparation Courses: These courses equip students with the knowledge and skills they need to meet the entrance requirements for most college programs or for admission to apprenticeship or other training programs.

Workplace Preparation Courses: These courses are designed to equip students with the knowledge and skills they need for direct entry into the workplace or for admission to certain apprenticeship programs and other training programs offered in the community. Co-operative education and work experience placements within the community are important components.

Open Courses: These courses are designed to broaden students' knowledge and skills in subjects that reflect their interests and to prepare them for active and rewarding participation in society. They are not designed with the specific requirements of universities, colleges or the workplace in mind.

Prerequisites are specified for many of the courses offered in grade 11 and 12. Students must ensure that they have completed the appropriate prerequisite as identified in the course calendar in order to select the course.

Transfer Courses: A transfer course is a partial-credit course that bridges the gap between courses of two different types in the same subject and grade. Students who revise their educational and career goals and who wish to change from one destination-related stream to another in a particular subject may often do so by taking a transfer course. Transfer courses enable students to achieve the expectations not covered in one course type but required for entry into a course in the next grade. Transfer courses will be offered for students who wish to change from one course type to another in the same subject between Grade 10 and Grade 11 or between Grade 11 and Grade 12. Based on demand, transfer courses may be offered through the summer school program.

THE ORGANIZATION OF COURSES:

Grade 12



Transfer Courses

Grade 11



Transfer Courses

Grade 10



Grade 9



THE ONTARIO STUDENT TRANSCRIPT (OST)

The Ontario Student Transcript (OST) provides a comprehensive record of a student's overall achievement in high school. This record will include all the credits gained by the students, including day school credits, continuing education credits or those earned through alternative means. The OST will include:

- all successfully completed credits in Grade 9 and 10 with percentage grades earned and credits gained
- all senior courses **taken or attempted** with percentage grades earned and credits gained. Courses from which a student has withdrawn subsequent to **5 days** following the **first reporting cycle** will appear with the mark earned up to the date of withdrawal. Students who repeat a course may earn a maximum of one credit for the course.
- identification of any course that has been substituted for a compulsory course
- confirmation of successful completion of the community involvement requirement
- final result on the provincial secondary school literacy test
- an indication of any extraordinary circumstances affecting the student's achievement in senior level courses.

THE ONTARIO STUDENT RECORD (OSR)

The Ontario Student Record is the record of a student's educational progress through schools in Ontario. The OSR contains achievement results, credits earned and diploma requirements completed and other information important to the education of the students.

Students and their parents (if the student is not an adult) may examine the contents of the OSR.

CODE OF STUDENT BEHAVIOUR and discipline including school policies on race relations and sexual harassment, school dress code and much more may be found in the **student /parent agenda** distributed to students on the first day of classes.

FULL DISCLOSURE

Grades 9 and 10 Courses

For grades 9 and 10 courses that begin on or after September 1999,

- **all courses successfully completed will be noted on the Transcript** and
- for repeated courses, only the highest successful mark will be recorded on the student Transcript

Grades 11 and 12 Courses

For grades 11 and 12 courses that begin on or after September 1999, if a student withdraws from a grade 11 or 12 course

- **on or before the 5th instructional day following the issuance of the first provincial report card (mid-term)**, the course *will not* be recorded on the student Transcript
- **after the 5th instructional day following the issuance of the first provincial report card (mid term)**, a 'W' will be entered in the credit column and the student's mark *at the time of the withdrawal* will be recorded in the achievement column.

Beginning September 1999, if a student repeats a grade 11, 12 or OAC course that the student has previously completed (either successfully or unsuccessfully),

- **each attempt and its mark will be shown on the OST.** The course with the lower mark will have an "R" entered in the credit column.

ASSESSMENT & EVALUATION

Student assessment and evaluation is an ongoing process. Teachers use a variety of tools such as assignments, demonstrations, projects, tests, examinations, etc. to assess student achievement. Student achievement is reported to parents as a percentage grade on the Ontario Provincial Report Card. The final grade will be determined as follows: 70% of the grade will be based on assessments and evaluations conducted throughout the course and 30% will be based on a final evaluation suitable to the content of the course. Students will receive a credit if they achieve a final grade of 50% or higher. More detailed information about evaluation and examination policies may be found in the student/parent agenda distributed to each student on the first day of classes.

REQUIREMENTS FOR THE ONTARIO SECONDARY SCHOOL DIPLOMA

A. All students who enter grade 9 on or after September 1, 1999 are eligible for this diploma. The total minimum number of credits required is 30. Eighteen credits are designated as compulsory. Twelve credits are designated as optional

Compulsory Credits (*total of 18*)

Students must earn the following compulsory credits in order to obtain the Ontario Secondary School Diploma:

- 4 credits in English (1 credit per grade)
- 3 credits in mathematics (at least 1 credit in Grade 11 or 12)
- 2 credits in science
- 1 credit in French as a second language
- 1 credit in Canadian history
- 1 credit in Canadian geography
- 1 credit in the arts
- 1 credit in health and physical education
- .5 credit in civics
- .5 credit in career studies

plus:

Group 1 – 1 additional credit in English, or French as a Second Language, or a Native Language, or a Classical or International Language, or Social Sciences and the Humanities, or Canadian and World Studies, or Guidance and Career Education, or Cooperative Education*

Group 2 – 1 additional credit in Health and Physical Education, or the Arts, or Business Studies, or Cooperative Education*

Group 3 – 1 additional credit in Science (Grade 11 or 12) or Technological Education (Grades 9-12)), or Cooperative Education*

Total Compulsory = 18

Elective = 12 which include the required Religion courses.

** A maximum of 2 credits in cooperative education can count as compulsory credits.*

The Requirements for the OSSD:

In order to earn the OSSD, a student must:

- earn 18 compulsory credits
- earn 12 optional credits
- complete 40 hours of community involvement activities
- successfully complete the provincial secondary school literacy test.

GRADE 10 LITERACY TEST – Accommodations, Deferrals and Exemptions

All students who entered Grade 9 in the 2000-2001 school year or in subsequent years must successfully complete the provincial secondary school literacy test in order to earn a secondary school diploma. The test will be based on the Ontario curriculum expectations for language and communication in all Grade 9 subject areas. Successful completion of the literacy test will be indicated on the Ontario Student Transcript. School boards are required to provide remedial assistance for students who do not complete the test successfully so that they will be better prepared to retake the test. Once students have successfully completed the literacy test, they may not retake the test in the same language. Please note, students who entered grade 9 in the 1999-2000 school year will not be required to complete the literacy test in order to earn their Ontario Secondary School Diploma

COMMUNITY INVOLVEMENT ACTIVITIES

Students are required to complete 40 hours of community involvement activities. These activities may be completed at any time during their years in the secondary program. The community involvement requirement is designed to encourage students to develop awareness and understanding of civic responsibility. The requirement is to be completed outside students' normal instructional hours. Students will maintain and provide a record of their community involvement activities using the Dufferin-Peel Passport to Community Service. This document is the responsibility of the student. The dates and times of student participation must be confirmed by the organizations or supervising persons. The principal will decide whether the student has met the requirements for both the ministry and the board for these activities. Further information is available in the Christian Community Involvement Passport Companion Parent Resource Manual which will be provided by the Teacher Adviser.

SPECIAL EDUCATION

As per Reg. 464/97(3) Dufferin-Peel Catholic District School Board's Special Education Advisory Committee (SEAC) includes two trustees and representatives from the following local associations:

- Association for Bright Children-Peel
- Autism Society of Ontario-Board Chapter of Peel
- Brampton/Caledon Community Living
- Community Living Mississauga
- Easter Seal Society
- Learning Disabilities Association-North Peel
- Peel Parents of Hearing Impaired Children /VOICE

This committee may be contacted through the Superintendent of Program (905) 890-0708 ext. 4261.

An annual special education plan is submitted by the Board on a yearly basis to the Ministry of Education. Information regarding the Board's special education policies, programs and services are outlined in the Special Education Parent Guide. These guides are available in all schools; they may be obtained by contacting the school principal or department head responsible for Special Education.

REQUIREMENTS FOR ONTARIO SECONDARY SCHOOL CERTIFICATE AND CERTIFICATE OF ACCOMPLISHMENT

The Ontario Secondary School Certificate will be granted on request to students who leave school before earning the Ontario Secondary School Diploma, provided they have earned a minimum of 14 credits distributed as follows:

- 2 credits in English
- 1 credit in Canadian geography or Canadian history
- 1 credit in mathematics
- 1 credit in science
- 1 credit in health & physical education
- 1 credit in arts or technological education
- 7 optional credits selected by the student

The Certificate of Accomplishment may be used to recognize the achievement of students who leave school before fulfilling the requirements for the Ontario Secondary School Diploma or Ontario Secondary School Certificate and who plan to take certain vocational programs or other kinds of further training, or who plan to find employment.

MUSIC CERTIFICATES ACCEPTED FOR CREDITS

A student who has successfully completed the requirements for one of the following may count a maximum of one non-Grade 12 university/college preparation credit towards the OSSD *in addition* to any other non-Grade 12 university preparation music credits earned in the school:

NOTE: The credit does not count as the one compulsory Arts credit as defined by the Ministry.

- Grade VII Practical and Grade I Rudiments of the Royal Conservatory of Music, Toronto
- Grade VII Practical and Grade III Theory of Conservatory Canada, London
- Collegial I Practical and Collegial I Theory of any conservatory of music in the province of Quebec.
- Grade VII Practical and Grade V Theory of Trinity College of Music, London, England
- Grade VII Practical and Grade VI Theory of the Royal Schools of Music, London, England

A student who has successfully completed the requirements for one of the following may count a maximum of one Grade 12 university preparation credit towards the OSSD in addition to a maximum of one other Grade 12 university preparation credit in music earned in the school:

- Grade VIII Practical and Grade II Rudiments of the Royal Conservatory of Music of Toronto
- Grade VIII Practical and Grade IV Theory of Conservatory Canada, London
- Collegial II Practical and Collegial II Theory of any conservatory of music in the province of Quebec.
- Grade VIII Practical and Grade VI Theory of Trinity College of Music, London, England
- Grade VIII Practical and Grade VIII Theory of the Royal Schools of Music, London, England

MINIMUM COURSE LOADS

- Grade 9** - A minimum course load of 8 credits
5 compulsory credits
2 optional credits
1 Religion credit
- Grade 10** - A minimum course load of 8 credits
5 compulsory credits
2 optional credits
1 Religion credit
- Grade 11** - A minimum course load of 8 credits including participation in a Religion course
- Grade 12** - A minimum course load of 6 credits including participation in a Religion course

COURSE CODING SYSTEM

Each course is identified by a code consisting of six characters.

For example:

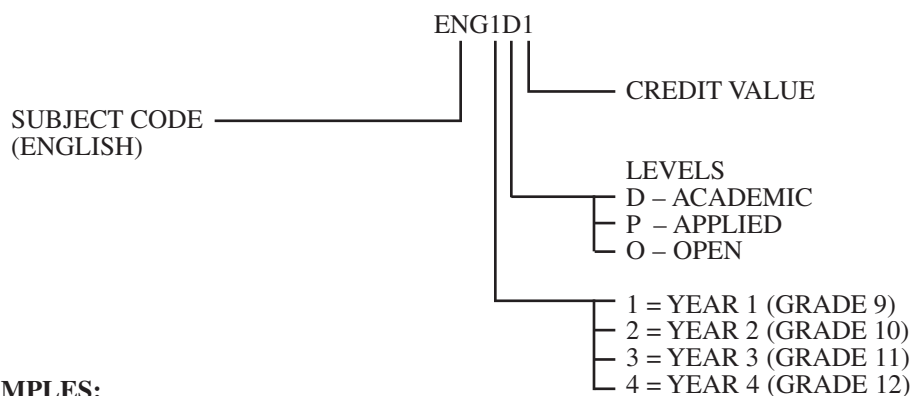

OTHER EXAMPLES:

- MFM 2P1 = MATHEMATICS AT THE GRADE 10 APPLIED LEVEL; ONE CREDIT VALUE
HRE 1O1 = RELIGION AT THE GRADE 9 OPEN LEVEL; ONE CREDIT VALUE
GLC 2O5 = CAREER STUDIES AT THE GRADE 10 OPEN LEVEL; .5 CREDIT VALUE
SCH 3U1 = CHEMISTRY AT THE GRADE 11 UNIVERSITY PREPARATION LEVEL; ONE CREDIT VALUE
CHW 3M1 = WORLD HISTORY AT THE GRADE 11 UNIVERSITY/COLLEGE LEVEL; ONE CREDIT VALUE
MBF 3C1 = MATHEMATICS OF PERSONAL FINANCE AT THE GRADE 11 COLLEGE LEVEL; ONE CREDIT VALUE
ENG 4U1 = ENGLISH AT THE GRADE 12 UNIVERSITY PREPARATION LEVEL; ONE CREDIT VALUE

SUMMARY OF COURSES

Courses	Grade 9	Grade 10	Grade 11	Grade 12
Arts				
Dance		ATC2O1	ATC3M1	ATC4M1
Dramatic Arts		ADA2O1	ADA3M1	ADA4M1
Guitar		AMG2O1	AMG3O1	
Instrumental Music	AMI1O1	AMI2O1	AMI3M1	AMI4M1
Media Arts		ASM2O1	ASM3O1	ASM4O1
Sculpture		AWP2O1		
Visual Arts	AVI1O1	AVI2O1	AVI3O1	AVI4M1
Vocal Music	AMV1O1	AMV2O1	AMV3M1	AMV4M1
Business Studies				
Business Leadership: Management Fundamentals				BOH4M1
Entrepreneurship: The Venture			BDI3C1	
Entrepreneurship: Venture Planning in an Electronic Age				BDV4C1
Financial Account Fundamentals			BAF3M1	
Financial Accounting Principles				BAT4M1
Information and Communication Technology in Business	BTT1O1			
Information and Communication Technology: Multimedia Solutions				BTX4C1
Information and Communication Technology: The Digital Environment			BTA3O1	
Introduction to Business		BBI2O1		
Marketing: Goods, Services, Events			BMI3C1	
Canadian and World Studies				
Analysing Current Economic Issues				CIA4U1
Canada: History, Identity, and Culture				CHI4U1
Canadian History Since World War I		CHC2P1 CHC2D1		
Canadian and International Law				CLN4U
Canadian and World Issues: A Geographic Analysis				CGW4U
Civics		CHV2O5		
Geography of Canada	CGC1P1 CGC1D1			
Physical Geography: Patterns, Processes and Interactions			CGF3M1	
The Individual and the Economy			CIE3M1	
Travel and Tourism: A Regional Geographic Perspective			CGG3O1	
Understanding Canadian Law			CLU3M1	
World History to the Sixteenth Century			CHW3M1	
World History: The West and the World				CHY4U1
Classical Studies and International Languages				
Spanish		LWSBD1	LWSCU1	LWSDU1

SUMMARY OF COURSES

Courses	Grade 9	Grade 10	Grade 11	Grade 12
English				
English	ENG1L1 ENG1P1 ENG1D1	ENG2L1 ENG2P1 ENG2D1	ENG3C1 ENG3U1	ENG4C1 ENG4U1
Media Studies			EMS301	
Ontario Secondary School Literacy Course, Grade 12				OLC401
Presentation and Speaking Skills			EPS301	
Studies in Literature				ETS4U1
The Writer's Craft				EWC4U1
English as a Second Language				
Beginning Communication in English	ESLAO1	ESLAO1	ESLAO1	ESLAO1
English in Daily Life	ESLBO1	ESLBO1	ESLBO1	ESLBO1
English for School and Work	ESLCO1	ESLCO1	ESLCO1	ESLCO1
Study Skills in English	ESLDO1	ESLDO1	ESLDO1	ESLDO1
Bridge to English	ESLEO1	ESLEO1	ESLEO1	ESLEO1
French as a Second Language				
Core French	FSF1P1 FSF1D1	FSF2P1 FSF2D1	FSF3O1 FSF3U1	FSF4O1 FSF4U1
Guidance and Career Education				
Advanced Learning Strategies: Skills for Success After Secondary School			GLE3O1	GLE4O1 GLS4O1
Career Studies		GLC2O5		
Cooperative Education			COOP2 COOP3 COOP4	COOP2 COOP3 COOP4
Leadership and Peer Support			GPP3O1	
Learning Strategies 1: Skills for Success in Secondary School	GLE1O1 GLS1O1	GLE2O1		
Health and Physical Education				
Exercise Science				PSE4U1
Healthy Active Living Education	PPL1OF	PPL2O1	PPL3O1	PPL4O1
Personal and Fitness Activities			PAF3O1	
Interdisciplinary Studies				
Families: Growth and Development in a Diverse Society				IDC4U1
Interdisciplinary Studies in Education				IDC4UE
Yearbook Publishing			IDC3O1	
Mathematics				
Advanced Functions				MHF4U1

SUMMARY OF COURSES

Courses	Grade 9	Grade 10	Grade 11	Grade 12
Calculus and Vectors				MCV4U1
Foundations for College Mathematics			MBF3C1	MAP4C1
Foundations of Mathematics	MFM1P1	MFM2P1		
Functions			MCR3U1	
Functions and Applications			MCF3M1	
Locally Developed Mathematics	MAT 1L1	MAT 2L1		
Mathematics of Data Management				MDM4U1
Mathematics for College Technology				MCT4C1
Principles of Mathematics	MPM1D1	MPM2D1		
Religious Education				
Church and Culture				HRE4M1 HRE4O1
Faith and Culture: World Religions			HRE3M1 HRE3O1	
Philosophy: Questions and Theories				HZT4U1
Religious Education	HRE1O1	HRE2O1		
Science				
Biology			SBI3C1 SBI3U1	SBI4U1
Chemistry			SCH3U1	SCH4C1 SCH4U1
Physics			SPH3U1	SPH4U1
Science	SNC1L1 SNC1P1 SNC1D1	SNC2P1 SNC2D1		
Environmental Science			SVN3M1 SVN3E1	
Social Sciences and the Humanities				
Challenge and Change in Society				HSB4M1
Fashion and Creative Expression			HNC3O1	
Food and Nutrition	HFN1O1			
Individual and Family Living		HIF2O1		
Food and Nutrition Sciences				HFA4M1
Issues in Human Growth and Development				HHG4M1
Parenting			HPC3O1	
Philosophy: Questions and Theories				HZT4U1
Technological Education				
Introduction to Computer Studies		ICS2O1		
Introduction to Computer Science			ICS3U1	
Computer Science				ICS4U1

MY EDUCATIONAL PLAN

NAME: _____

GRADE 9	GRADE 10	GRADE 11	GRADE 12
1. RELIGION	1. RELIGION	1. RELIGION	1. RELIGION
2. ENGLISH	2. ENGLISH	2. ENGLISH	2. ENGLISH
3. MATHEMATICS	3. MATHEMATICS	3. MATHEMATICS	3.
4. SCIENCE	4. SCIENCE	4.	4.
5. GEOGRAPHY	5. HISTORY	5.	5.
6. FRENCH	6. CAREER STUDIES (.5) AND CIVICS (.5)	6.	6.
7.	7.	7.	7.
8.	8.	8.	8.
TOTAL:	TOTAL:	TOTAL:	TOTAL:

Students intending to gain the OSSD will need these additional compulsory credits:

1 Arts Credit*

1 Health and Physical Education*

*It is advisable to complete these compulsory credits in grades 9 or 10.

1 additional credit in English, or French as a Second Language, or a Native Language, or a Classical or International Language, or Social Sciences and the Humanities, or Canadian and World Studies, or Guidance and Career Education, or Cooperative Education*

1 additional credit in Health and Physical Education, or the Arts, or Business Studies, or Cooperative Education*

1 additional credit in Science (Grade 11 or 12) or Technological Education (Grades 9-12)), or Cooperative Education*

COURSE SELECTION AND PROGRAM PLANNING

All students are strongly encouraged to seek the assistance of their present teachers, a counsellor and parents when choosing courses and streams. A student's academic abilities, career goals and personal interests should be considered when selecting courses. Please be sure to choose streams that are challenging and in which success can be achieved.

Students who are uncertain about their future are advised to keep open as many subject areas as possible by choosing courses that will give them a background common to several career choices. Several resources pertaining to the admission requirements for entry into post-secondary programs are available in Guidance. Counsellors are trained to help students check these requirements and to assist in the planning of an individualized program.

The final responsibility for course selection rests with the student and her parents/guardian. **It is extremely important that course selection for all students be as accurate as possible, since often, course changes cannot be made due to timetable conflicts or class sizes.** Note that courses will run based on student requests and are subject to the deliberation of SAAC (Staff Allocation Advisory Committee).

SCHEDULE CHANGES

It is extremely important that course selections be made as accurately and carefully as possible. Once courses have been approved for the 2009/2010 school year and staffing allocated as required, course changes may not be possible due to timetable conflicts or class size.

CHANGES WILL BE MADE TO COURSE SELECTIONS ONLY IF:

- a) the change is required due to a subsequent failure(s);
- b) the student receives a credit(s) in summer school;
- c) new students to the school are confirmed to be incorrectly placed in their course(s);
- d) there are special individual circumstances.

These changes will only be made during the first **two** weeks of classes.

Level changes in a subject may only be made during the first **six** weeks of classes.

The decision to grant any schedule change is dependent upon:

- a) the student's attendance at all scheduled classes
- b) class size
- c) compatibility with a student's timetable.

After consultation with a guidance counsellor, a Request to Change Form will be sent home for parents' comment and signature for any student who has not attained the age of majority. The student is expected to attend all classes until official approval has been granted by the Guidance and Career Education Department.

Drops will be allowed as follows: Grade 12 Courses – any request to drop a course must be made by January 31st, 2010. Students must maintain a minimum of 6 credits.